

FITMENT INSTRUCTIONS

Alu-CabTM



Hercules Roof Conversion to Landcruiser 78 series

All rights reserved. No part of this document may be reproduced, translated, stored in a retrieval system, or transmitted, in any form or by any means, electronic, mechanical, photocopying, recording or otherwise, without prior written permission of the owner.

Review all instructions information carefully before installation.

Any damages, direct or incidental to the installer and/or property due to incorrect installation of any parts are the responsibility of the installer. Due to the various applications and fitment options available, the responsibility lies with the user to ensure all mounting points are secure and tight before every trip. If unsure, consult with your Distributor regarding the operations of our products.

Users are advised to be mindful of the load they are carrying and drive in accordance with road conditions.

DISCLAIMER

Alu-Cab

1. Hercules roof conversion Fitment – Tools, Fasteners & Materials

The tables below show the equipment, i.e. tools and fasteners required to start the Hercules roof conversion fitment onto a Landcruiser 78 series.

1.1. Tools & Items Required:

TOOLS	ITEM
Ratchet/impact wrench	Turpentine
Nibbler	Cloth
Adhesive applicator	sealant, silicone or Sika flex
Drill	Masking tape
Rivnut gun	Rust preventative paint
Grinder	
Star screw driver	
10,12,13 spanner	
6mm Allen key	
Plastic block	
Hammer	
Centre punch	

1.2 Fasteners supplied: (Included with Hercules)

ITEM	QTY
M8 LF RIVNUT	4
M8X20 HEX BOLT SS	12
M8X24MM OVERSIZE WASHER SS	20
M8 NYLOC NUTS SS	8
M6 Spring Washers SS	4
M6X20 HEX BOLT SS	4
M6X12MM FLAT WASHER SS	4
M6 NUTCAP	4
M8 NUTCAP	4
M8 SPRING WASHER SS	4

NB: The color of the vehicle images might vary as additional improvements have been made over time.

1.3 Hardware Required: (Included with Hercules)

ITEM	DESCRIPTION	QTY
322--HERC-RER-MNT-BRKT-01	REAR MOUNTING BRACKET	2
322-HERC-FNT-MNT-BRKT-01	FRONT MOUNTING BRACKET	2
322-CONSOLE-ASSY-01	CONSOLE ASSEMBLY	1
322-SID-COV-ASSY-01	SIDE COVER ASSEMBLY	1
322-HERC-CONS-LGHT-COV-ASSY-01	HERCULES LIGHT COVER	1

THIS ASSEMBLY TO BE FITTED TO BASE

ITEM NO.	PART NUMBER	DESCRIPTION	QTY
1	322-HERC-CONS-FNT-COV-01	CONSOLE FRONT COVER	1
2	322-HERC-CONS-01	CONSOLE	1
3	RUB&P - (Ø.15m)	PINCHWELD RUBBER	2
4	RUB&P-1400mm	PINCHWELD RUBBER	1
5	RIV-4810AS	BLIND RIVET	3
6	RUB&P - (1110mm)	PINCHWELD RUBBER	1
7	CRPAEBN - (1110mmx202mm)	TC&F - RB EBONY CARPET	1

REV.	DESCRIPTION	ECO	DATE	APPROVED
00	RELEASED FOR PRODUCTION		2020-08-31	System Administrator

TOLERANCES TO ASSUME UNLESS INDICATED OTHERWISE	322-HERC-CONS-FNT-COV-01	SHEET: A3
CONSOLE ASSEMBLY	322-HERCULES ROOF CONVERSION	SCALE: 1:10
DATE: 2020-08-19	322-CONSOLE-ASSY-01	REV: 00

Alu-Cab

DETAIL B SCALE 1:1

DETAIL A SCALE 1:5

ASSEMBLY TO BE PACKED SEPARATELY

ITEM NO.	PART NUMBER	DESCRIPTION	QTY
1	322-HERC-SID-COV-APNL-01	SIDE COVER PANEL 01	1
2	322-HERC-SID-COV-APNL-02	SIDE COVER PANEL 02	1
3	HEX-AM6 16	M6x16 HEX BOLT SIS	4
4	F1WAS6	M6x12mm FLAT WASHER SIS - DIN 125	4
5	NCAP-AM6	NUT CAP-06mm	4
6	RIV-LF-AM6	M6 LF RIVNUT	4
7	20x20 SBR FOAM 675mm	FOAM RUBBER	2
8	24x5 SBR FOAM 675mm	FOAM RUBBER	2
9	RUB-CH-S-350mm	RUBBER CHANNEL	2
10	RUB-CH-S-405mm	FOAM RUBBER	2

REV.	DESCRIPTION	ECO	DATE	APPROVED	REV
00	RELEASED FOR PRODUCTION		2020-08-31	System Administrator	00

TOLERANCES TO ASSUME UNLESS INDICATED OTHERWISE	DESCRIPTION	SHEET	SHEET
±0.05	HERCULES ROOF CONVERSION	A3	1 of 1
±0.10			
±0.20			
±0.30			
±0.50			
±1.00			
±2.00			
±3.00			
±5.00			
±10.00			

322-SID-COV-ASSY-01

ITEM NO.	PART NUMBER	DESCRIPTION	QTY
1	322-HERC-CONS-LIGHT-COV-01	CONSOLE LIGHT COVER	1
2	F1WAS	M6x10mm FLAT WASHER SIS - DIN 125	8
3	NY-AM5	M5 NYLOC NUT SIS	4
4	NCAP-AM5	NUT CAP-05mm	4
5	BHD-M5x35	M5x35 BHD BOLT SIS	4

REV.	DESCRIPTION	DATE	APPROVED	REV
00	RELEASED FOR PRODUCTION	2021-01-28	System Administrator	00

TOLERANCES TO ASSUME UNLESS INDICATED OTHERWISE	DESCRIPTION	SHEET	SHEET
±0.05	HERCULES LIGHT COVER	A3	1 of 1
±0.10			
±0.20			
±0.30			
±0.50			
±1.00			
±2.00			
±3.00			
±5.00			
±10.00			

322-HERC-CONS-LIGHT-COV-ASSY-01

**IMPORTANT
NOTICE**



It is important to check for any leaks that may be occurring through the roof or door areas before starting the roof conversion. This will ensure that you are aware of problem areas that may arise when the roof conversion is completed.



STEP 1 :

Once you've checked the vehicle for any leaks, you can then set about preparing the vehicle by covering any areas inside the vehicle that may be susceptible to damage when removing the roof. Once all the parts are covered you can begin stripping the interior roof linings, seat belt mounts, and anything that may be attached or affected by the fact that you are about to remove the roof.



WARNING

Always wear appropriate PPE (Personal protection equipment) when fitting this product. Although the mounting kit is designed to be DIY, if you have any doubts or concerns, contact an accredited fitment centre to carry out the work. Alu-Cab will not be liable for any injury to persons, and/or damage to products and/or vehicles.

STEP 2 :

Remove the light from the top hat stiffener (this light will be relocated to the console).



STEP 3 :

Unbolt the A, B & C top hats



STEP 4:

Be sure that when removing all interior window linings, sun visors, mirror mounts etc, that you store them in a safe place, as some of these parts will be re-installed during the installation of the Hercules roof conversion.





STEP 5 :

Remove the rear brake light from the roof.





STEP 6 :

Measure and mark the roof 70mm along the sides and rear end of the vehicle and 100mm on the front side of the vehicle as seen below.

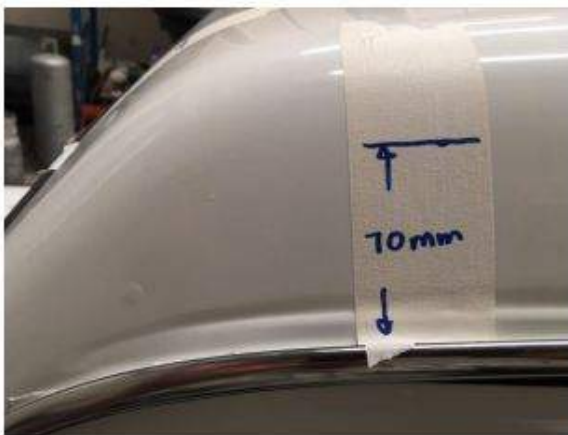

SIDE FRONT

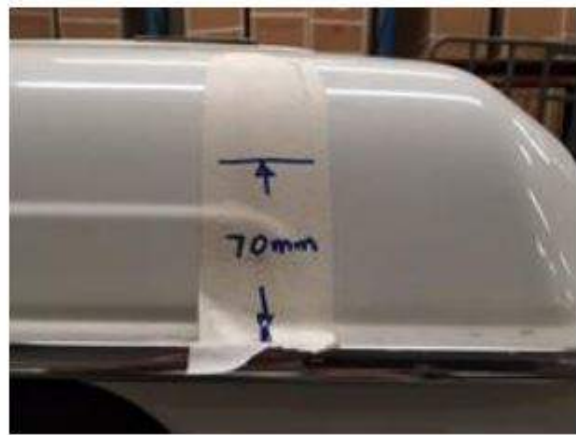

SIDE BACK

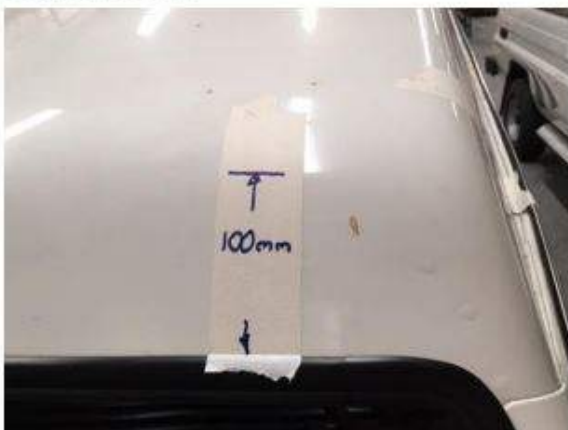

FRONT

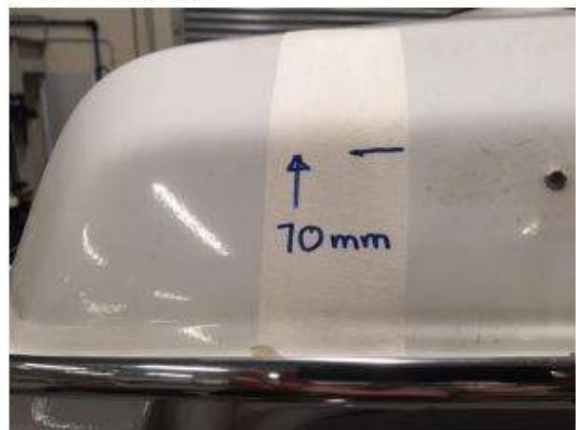

REAR

STEP 7 :

You will then need to drill access holes at the corners of the roof so that you can use your Nibbler tool to cut the roof off.

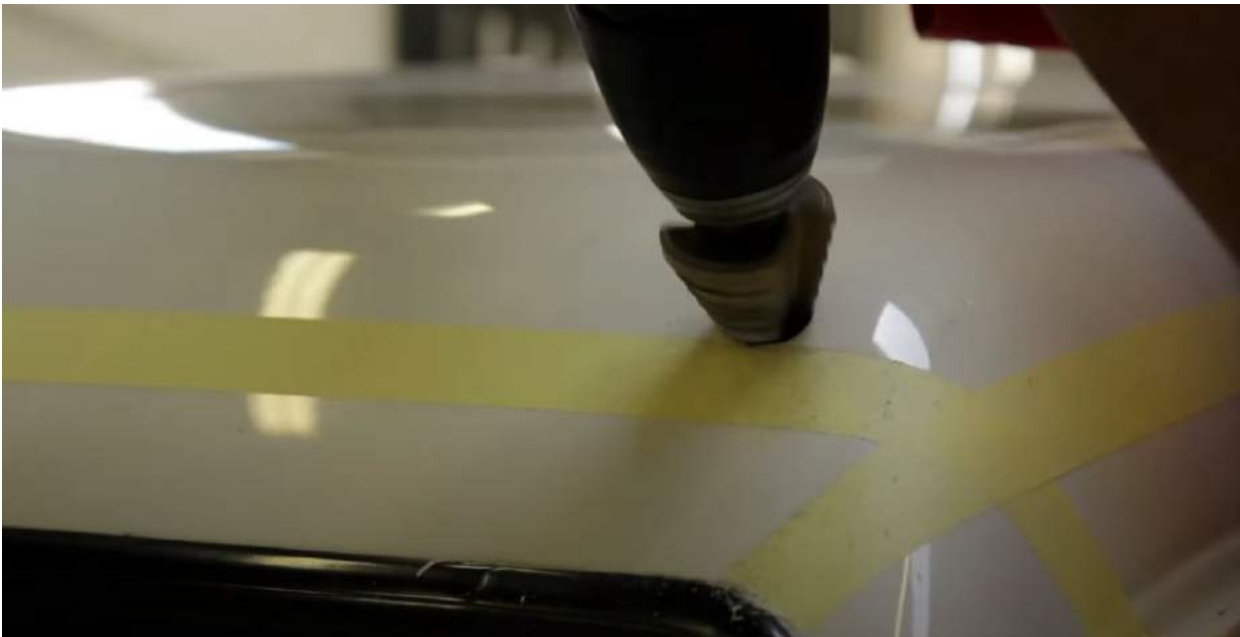

STEP 8 :

Once the holes has been drilled, you can now proceed to cut the roof off using the Nibbler tool as seen below.





STEP 9 :

Now you can remove the roof.



STEP 10 :

You will then need to drill the A-top hat mount loose on the areas which are spot welded.





You will need to fit 2 x M6 Rivnuts to the two bottom holes on either side of the A-Top hat mount. These holes will be used to mount the side cover panels provided with the roof conversion.

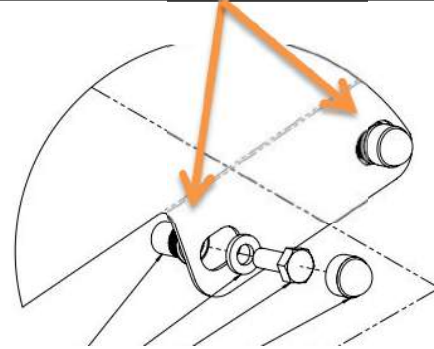

Mark and cut 20mm off from the top of the B & C top hat mounts as seen below.



Drill the bottom holes of the B & C top hat mounting points, and fit with the M8 rivnuts supplied in the kit.



STEP 11 :

You may now proceed to fit the mounting brackets supplied in the kit at the B & C top hat mounting points as seen below.



Apply a rust preventive paint to the roof along the section which has been removed.

STEP 12 :

Dry fit the roof conversion into position, using two bars to balance the conversion on top of the vehicle. This will help you to make the necessary markings for the mounting kit.



Mark your holes positions and drill out the holes on the base mounting plate.

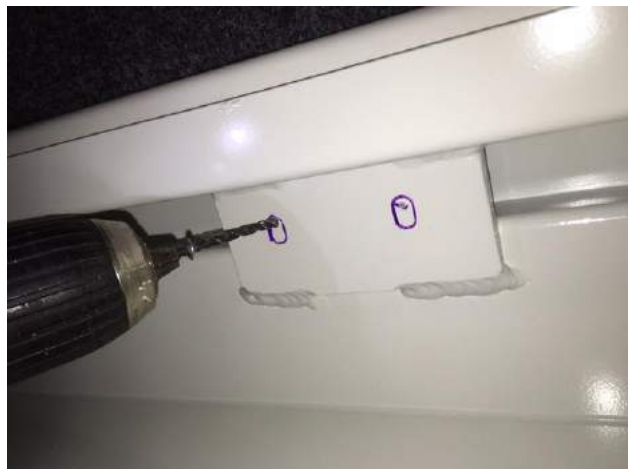

Apply Sikaflex to the vehicle all along the sides and rear, As seen below (the color of the adhesive depends on the color of the roof conversion you have).





Lower the roof into position.



Clamp down the roof on the rear and sides of the vehicle for a proper seal.



Bolt the mounting brackets to the vehicle and base and tighten as seen below.



Once the roof conversion is bolted down, you may now proceed to seal the sides and all around the roof as seen below.





STEP 13:

Remove the bottom bolts from the throw over latches and drill through the vehicle roof to secure the bottom bolts into place.



STEP 14:

Prepare the existing roof light wire for soldering and extend the wire to reach the console and fit the OEM light which was removed from the B top hat to Hercules console as seen in the images below.





Use the bolts supplied to fit the OEM light into the console.

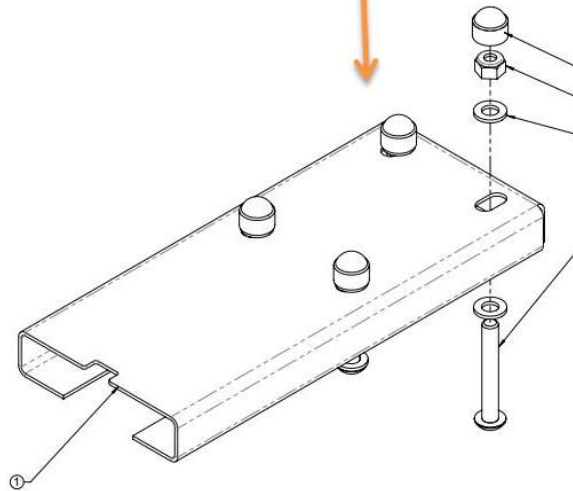

STEP 14:

The final part of the fitment is to fit the two side panels supplied in the kit. There is a left side panel and a right side panel fitted with rubber and foam to prevent these parts from rattling.

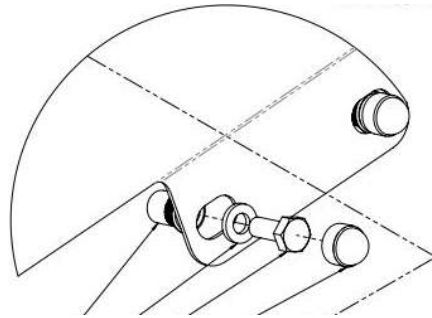

NB: Allow 12 hours for the adhesive sealant to set and 48 hours to cure before operating the Roof Conversion.

**By now you should have successfully fitted your
Land Cruiser Hercules Roof Conversion.**

All that's left to do is pull the vehicle outside, pop open your new roof, fit the spring poles and see how well your new roof conversion works.



Should you experience any problems, please contact us so that we can assist you.

Enquiries: queries@alu-cab.co.za
Tel: +27 21 703 3028