

GENERAL ARRANGEMENT ONLY

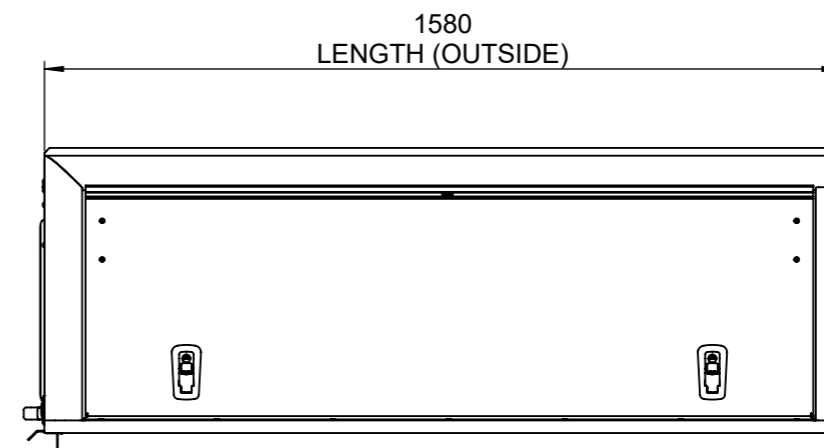
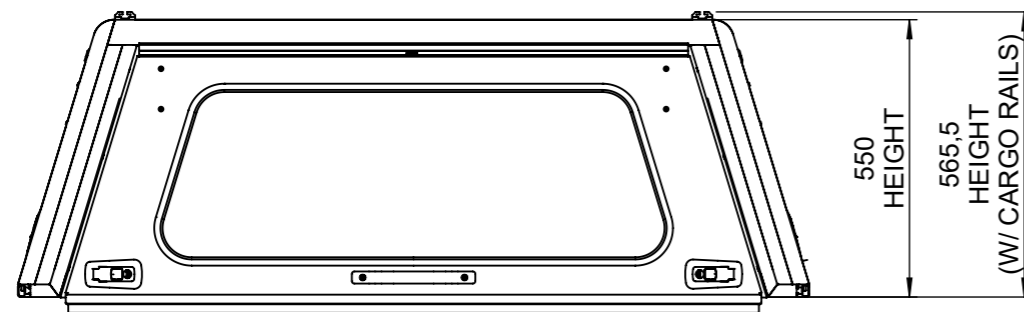
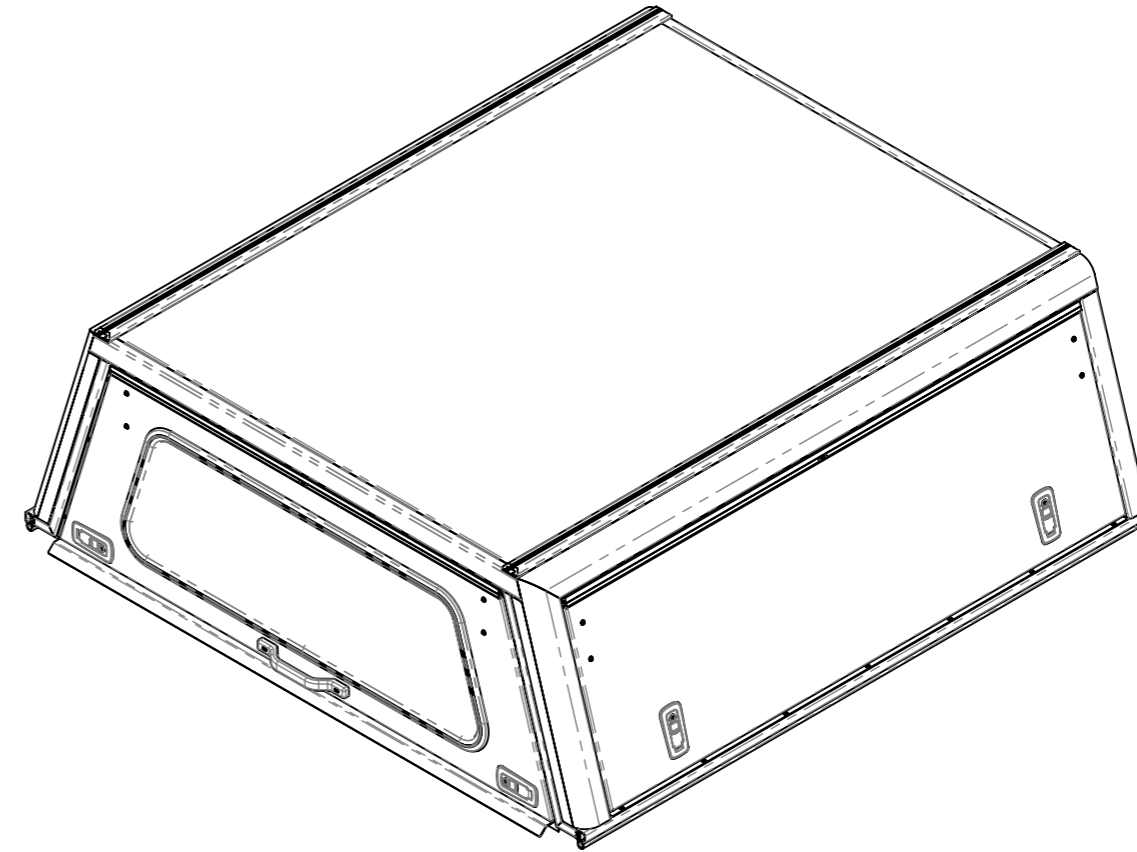
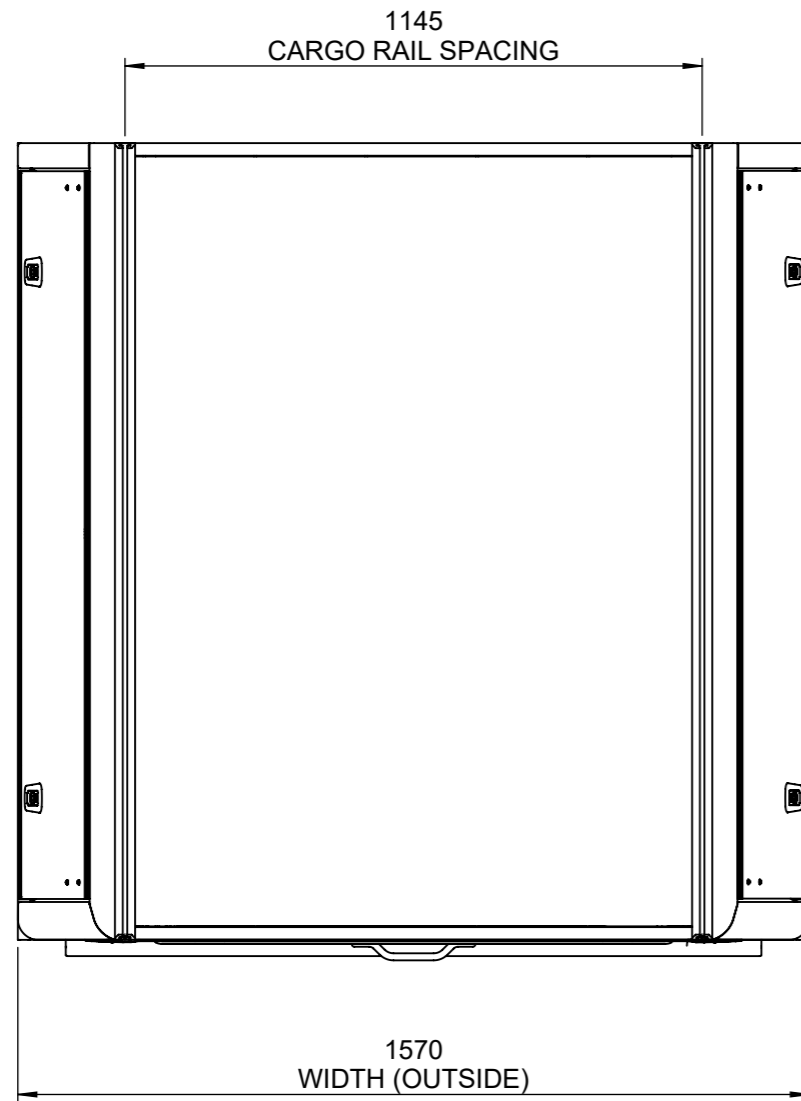

TOLERANCES TO ASSUME
UNLESS INDICATED OTHERWISE

NOM DIMENSION	RANGE (mm)	TOLERANCE
0.50	- 3.00	± 0.10
3.00	- 6.00	± 0.15
6.00	- 30	± 0.20
30	- 120	± 0.30
120	- 400	± 0.50
400	- 1000	± 1.00
1000	- 1000<	± 2.00

DESCRIPTION:
TOYOTA HILUX (VIGO) DC - GA

PROJECT:
EXPLORER CANOPY

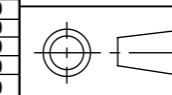

DRAWN BY:
B NEEDHAM

DATE:
28.02.2020

THE INFORMATION CONTAINED WITHIN THIS DOCUMENT
IS THE INTELLECTUAL PROPERTY OF ALU-CAB (PTY) LTD

SHEET:
A4

SCALE:
1:15

SHEET
1 of 1

Alu-CabTM
ULTIMATE OVERLAND PRODUCTS

DRAWING NO. **EX CANOPY GA - TOYOTA HILUX (VIGO) DC 00**

REV

REVISIONS

REV.	DESCRIPTION	ECO	DATE	APPROVED
1				
2				
3				
4				
5				