

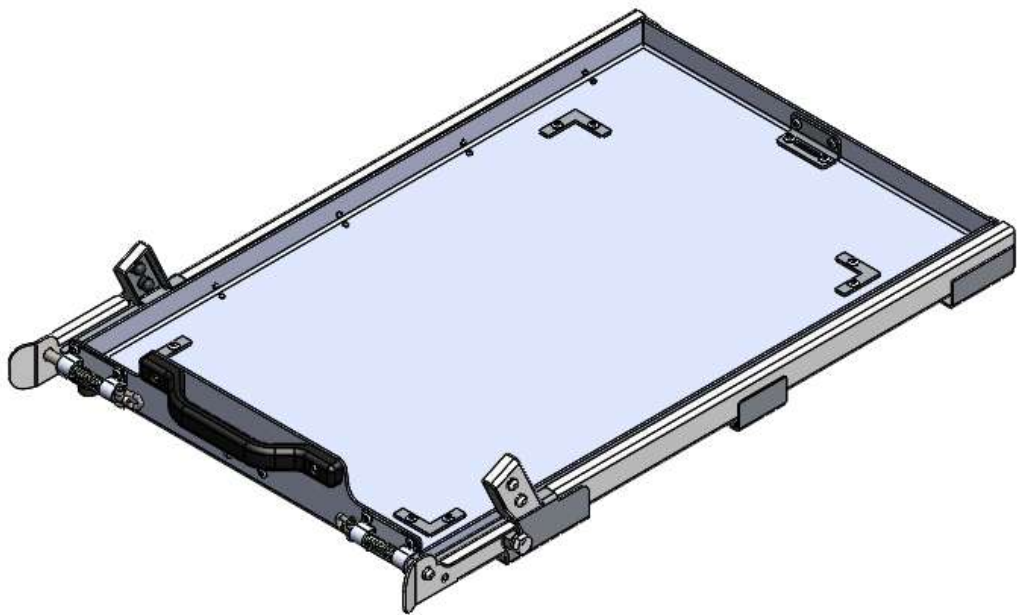

Tilting Fridge Slide Fitment Instructions



1. Fridge Slide – Tools, Fasteners & Materials

The tables below show the equipment, i.e. tools, fasteners, hardware and consumables required to start and finish the fitment of the Fridge Slide.

1.1 Hardware Supplied with fridge slide:

ITEM NO.	PART NUMBER	DESCRIPTION	QTY.
1	434-ASSY-01-00	BOTTOM RAIL ASSEMBLY	1
2	434-ASSY-02-00	TRAY ASSEMBLY	1
3	434-FS-LOCATOR-01-00	Fridge Slide Locator	4
4	Rivet Ø4.8x11	Rivet Ø4.8x11	8
5	M8x20 HEX BOLT	M8x20 HEX BOLT	4
6	M8 FLAT WASHER	M8 FLAT WASHER	8
7	M8 NYLOC NUT	M8 NYLOC NUT	4

<u>TOOL</u>	<u>PURPOSE</u>
Allen Key	Fastening various bolts
Ø9mm & Ø5mm Drill Bit	Drilling holes
Drill	Drilling holes
Rivet gun	Riveting locator brackets to tray
13mm spanner	Spanner to tighten various bolts
Ratchet	Fastening various bolts

.2 Tools required to fit fridge slide:

Part Identification:

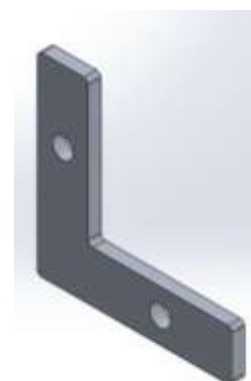
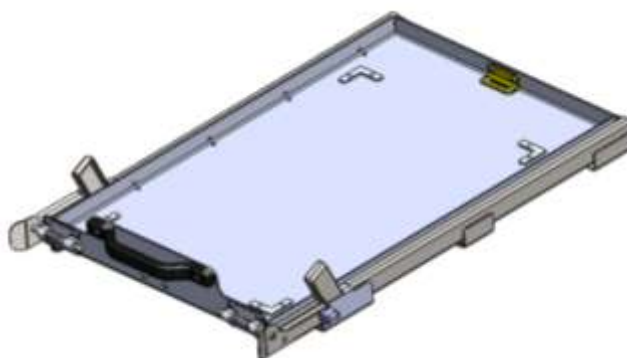

2. Figure 1: Fridge Slide Assembly

Figure 2: Fridge Slide Locator

Step 1: Drill holes into mounting surface

To mount the fridge slide, you will need to drill holes into the surface you will mount it to so that you can bolt the fridge slide frame down. Before drilling any holes ensure that the position for the fridge slide is close enough to the edge of the mounting surface so that it can tilt downwards as shown below in figure 3.



Figure 3: Fridge Slide in Tilted down position

Remove the fridge slide tray from the fridge slide frame in order to access the mounting holes. The recommended hole locations are shown circled in red in figure 4 below. If there is a clash with the recommended holes, the other holes in the frame can be used. Mark out the hole locations and using a hand drill and Ø9mm drill bit drill the holes.

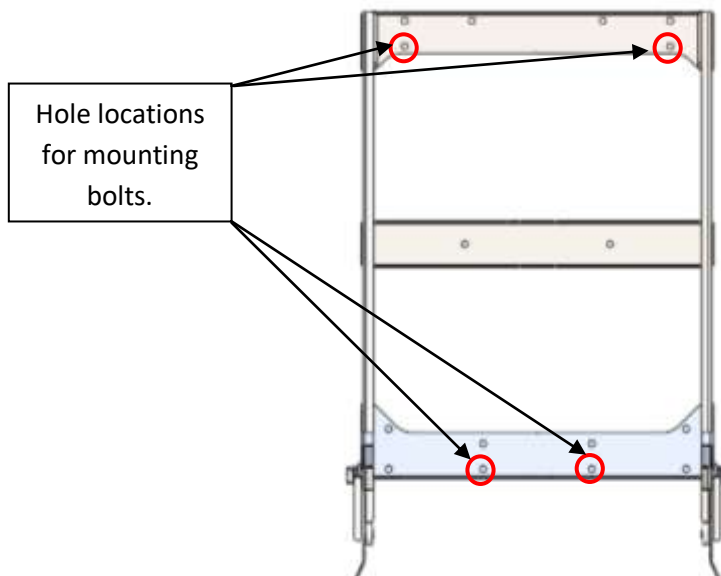

Figure 3: Hole positions on Fridge Slide Frame.

Step 2: Bolt Fridge Slide frame to mounting surface

Using the M8 bolts, nyloc nuts, washers and plastic nut caps provided bolt the fridge slide frame to the mounting surface as shown below in figure 4.

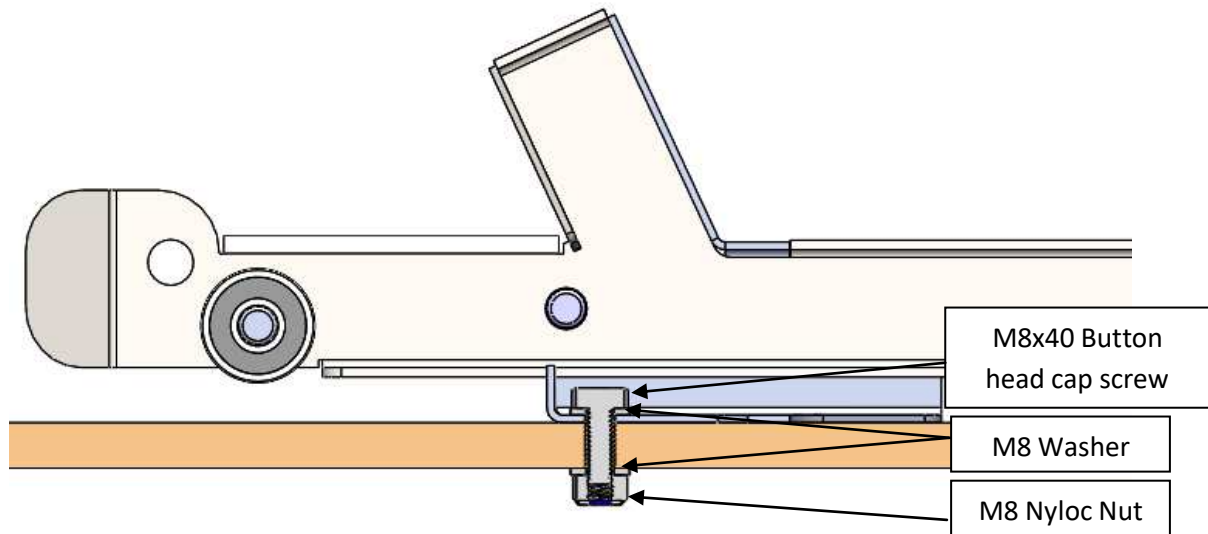

Figure 4: Sectioned side view of Fridge Slide Frame

Step 3: Fit locator brackets to fridge slide tray

There are 4 fridge slide locator brackets provided with the fridge slide, these are used to keep your fridge from moving around during travelling. The 4 locators are installed next to the feet of the fridge to prevent movement. Place the fridge in the centre of the fridge slide tray and place the locators hard up against the legs of the fridge. Mark off the hole positions and using a $\text{Ø}5\text{mm}$ drill bit, drill the holes. Use a rivet gun to rivet the locator brackets in place. See below for figure

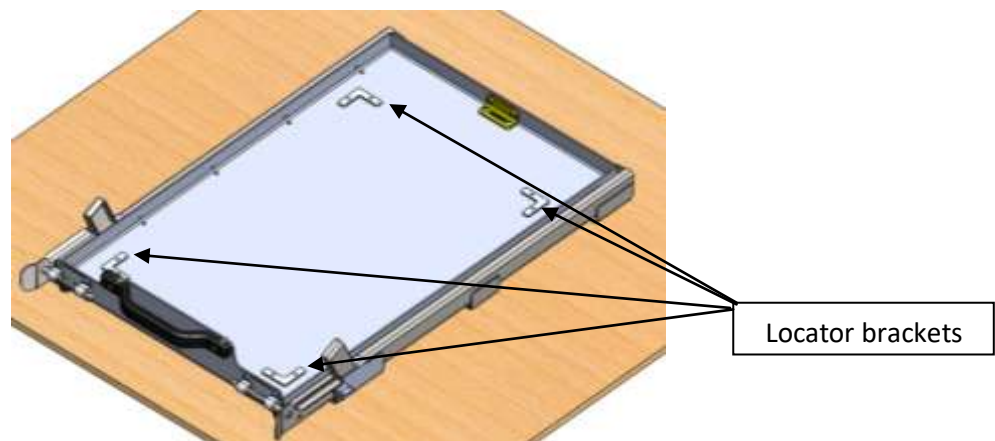

Figure 5: Locator brackets installed.

Step 4: Ratchet strap your fridge to the fridge slide tray.

Ratchet strap your fridge to the fridge slide tray using ratchet straps and the slots as circled below in figure 6. Your fridge is now installed.

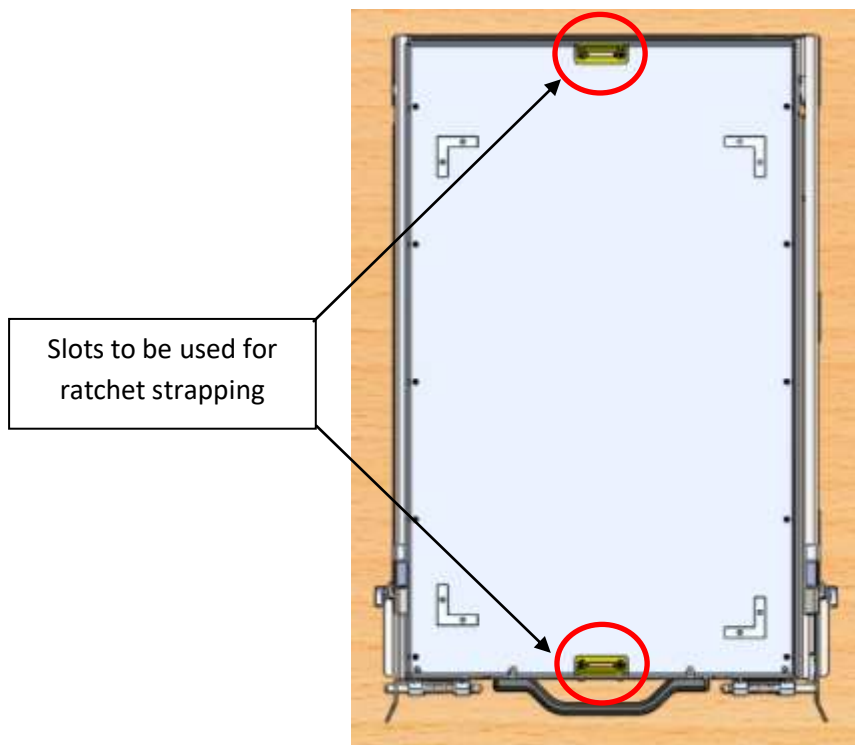

Figure 6: Ratchet strap slots.



Figure 6: Ratchet strapped fridge.

To add a non tilting option:

1. Add Item 1 as shown and to the opposite side as well with supplied bolts as shown below

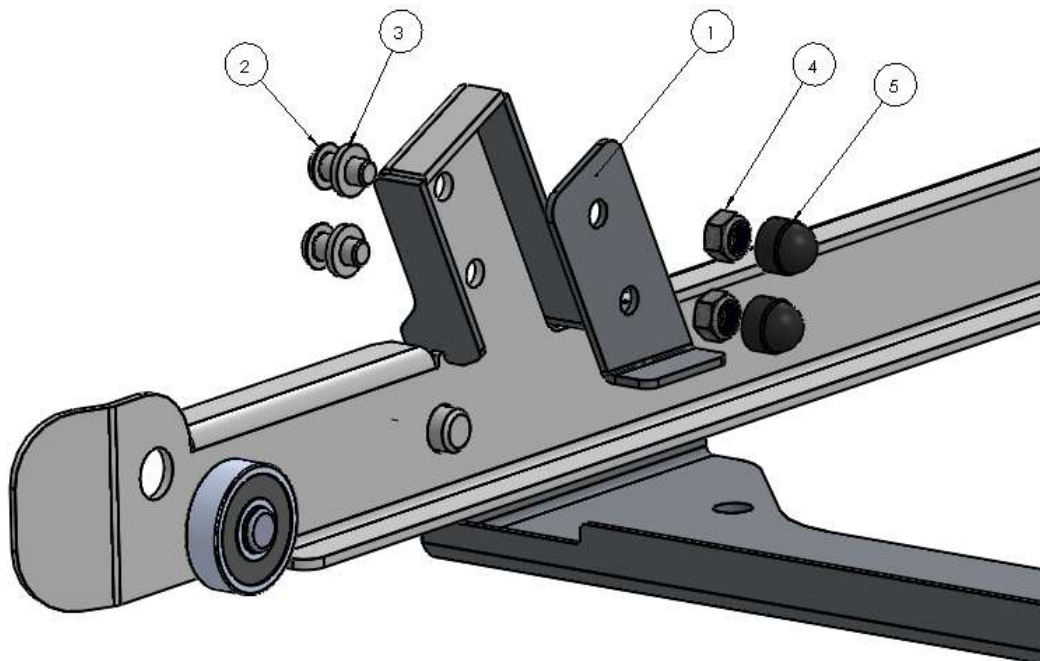

ITEM	PART NUMBER	DESCRIPTION	MATERIAL	QTY.
1	434-TILT-STP-LH-01-00	Tilt stopper LH	AISI304 (2mm)	1
1 OPP.	434-TILT-STP-RH-01-00	Tilt Stopper RH	AISI304 (2mm)	1
2	M6x16 Button Head Screw	M6x16 Button Head Screw	AISI316	4
3	M6 Flat Washer	M6 Flat Washer	AISI316	4
4	M6 Nyloc Nut	M6 Nyloc Nut	Galvanized Steel	4
5	M6 Nut Cap	Nut Cap	PE Low/Medium Density	4