

FITMENT INSTRUCTIONS

Alu-Cab™



Roof Box (Large & Small) to Alu-Cab Load Bars

All rights reserved. No part of this document may be reproduced, translated, stored in a retrieval system, or transmitted, in any form or by any means, electronic, mechanical, photocopying, recording or otherwise, without prior written permission of the owner.

Review all instructions information carefully before installation.

Any damages, direct or incidental to the installer and/or property due to incorrect installation of any parts are the responsibility of the installer. Due to the various applications and fitment options available, the responsibility lies with the user to ensure all mounting points are secure and tight before every trip. If unsure, consult with your Distributor regarding the operations of our products.

Users are advised to be mindful of the load they are carrying and drive in accordance with road conditions.

DISCLAIMER

Alu-Cab

1. Roof Box Fitment - Tools, Fasteners & Materials

The tables below show the equipment, i.e tools, fasteners, hardware and consumables required to complete the fitment of the Alu-Cab Roof Box, to Alu-Cab Load Bars:

Hardware supplied with the Roof Box kit:

Roof Box	Roof Box Full Assembly	1
Mount Plates	Mounting Plate	8
M8x20 Hex Bolt	M8x20 Hex Bolt	8
M8 Nyloc Nut	M8 Nyloc Nut	8
M8 Nut Cap	M8 Plastic Nut Cap	8
Rubber Strip	1300mm Length Rubber Strip	2
R-Clip	R-Clip	1

Tools required to fit the Roof Box kit:

Tool	Purpose
13mm Spanner/Ratchet	Fastening Nuts and Bolts
Size 6 Allen Key	Fastening Bolts
Drill Bit 4mm	Pilot Hole
Drill Bit 9mm	Mounting Hole



WARNING

Always wear appropriate PPE (Personal protection equipment) when fitting this product. Although the mounting kit is designed to be DIY, if you have any doubts or concerns, contact an accredited fitment centre to carry out the work. Alu-Cab will not be liable for any injury to persons, and/or damage to products and/or vehicles.

2. Fitting the Roof Box Kit

Step 1: Removing Load Bar End Caps

In preparation for the Fitment of the Roof Box, we first need to remove the Alu-Cab Load Bar End Caps off of the Load bars, already mounted to the base unit, as shown below:

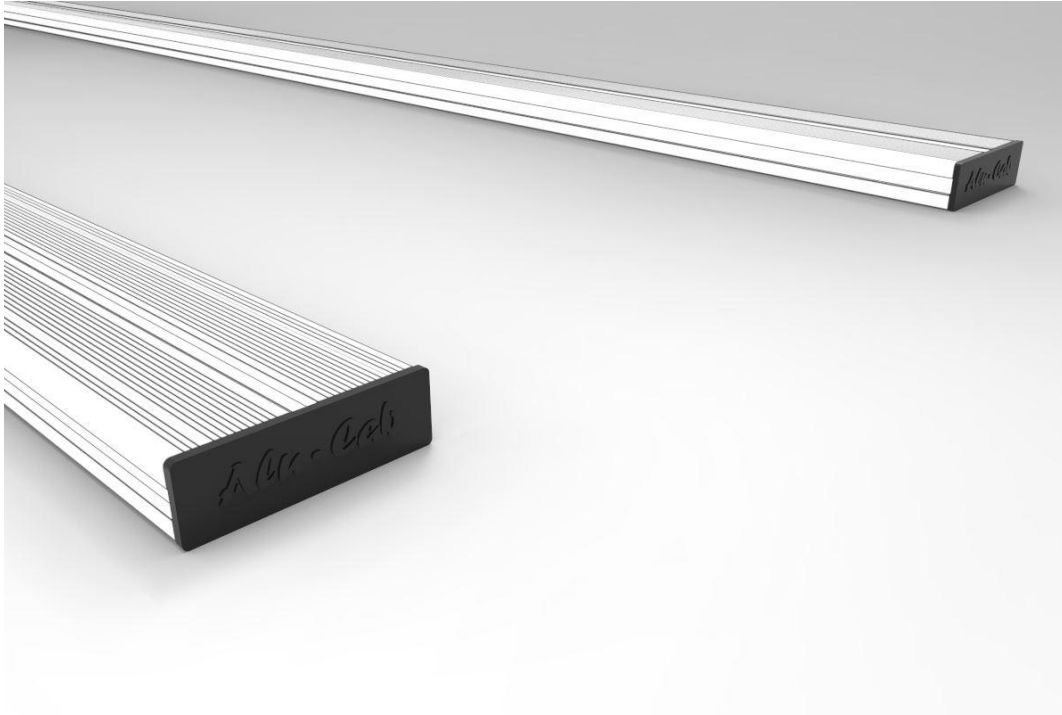

Figure 1: Load Bars with End Caps

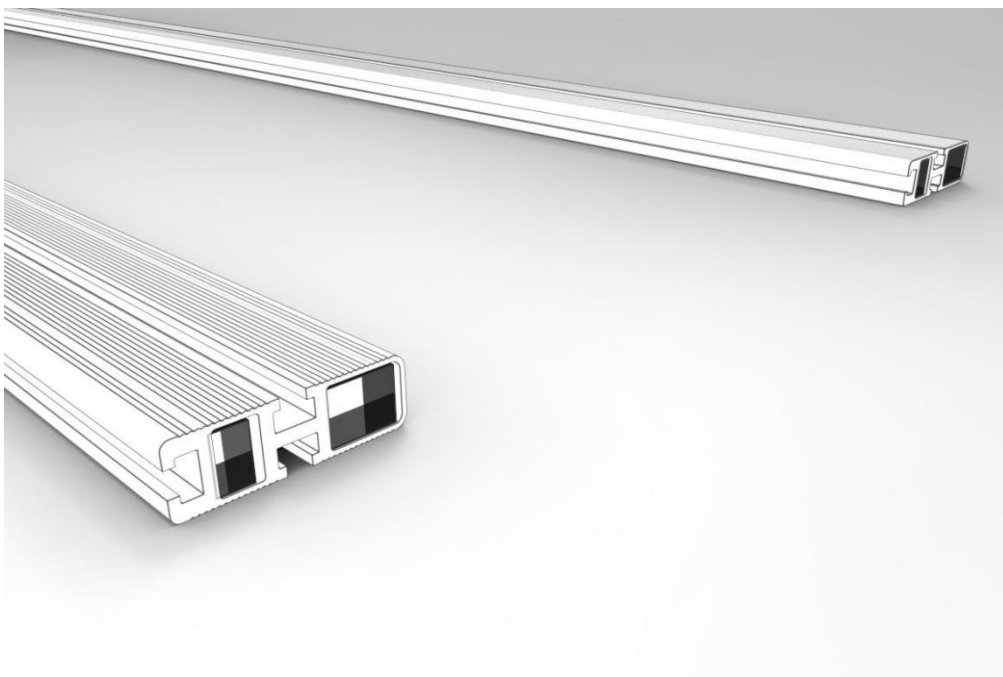

Figure 2: Load Bars with End Caps removed

Step 2: Drilling Roof Box Floor Holes

The next step is to drill the mounting holes for the Roof Box, through the base of the Roof Box. The process here is to:

1. Measure the centre distance between the Top Nut Slots of the Load Bars, as you have distanced the Load Bars equally they should be the same either side. This distance will give you the measurement between your 2 sets of holes on the bottom of your Roof Box Base.

2. Now you should place your Roof Box on the mounted Load Bars in a position where it doesn't interfere with you Tent, Awning etc or any other accessories on your roof. Once the position is fine you can mark how far forward or backward it sits in order to clear everything, so that we can align our holes with this.

3. We can now drill our pilot holes ($\pm 4\text{mm}$) spaced out evenly to distribute load, along the marks we made, across the base of the Roof Box. As shown in the example images below.

4. Now we can Drill with our 9mm drill bit through the pilot holes.

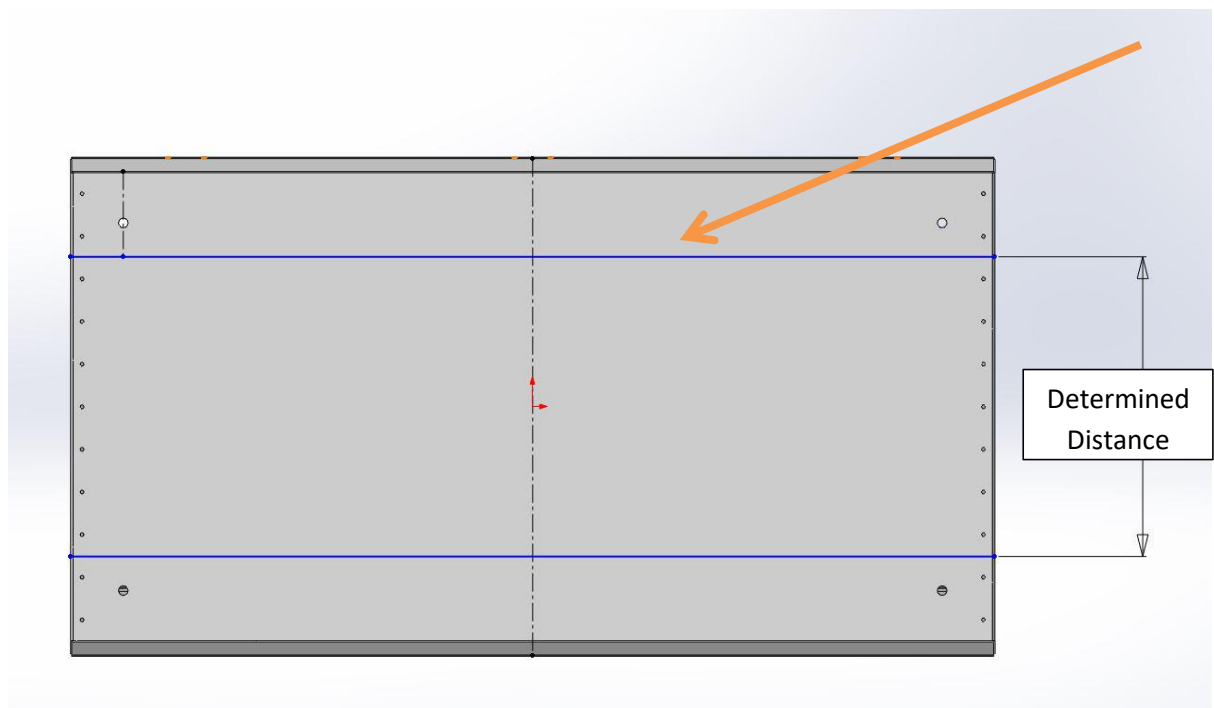

Figure 3: Load Bar Distance Measurement and Marking

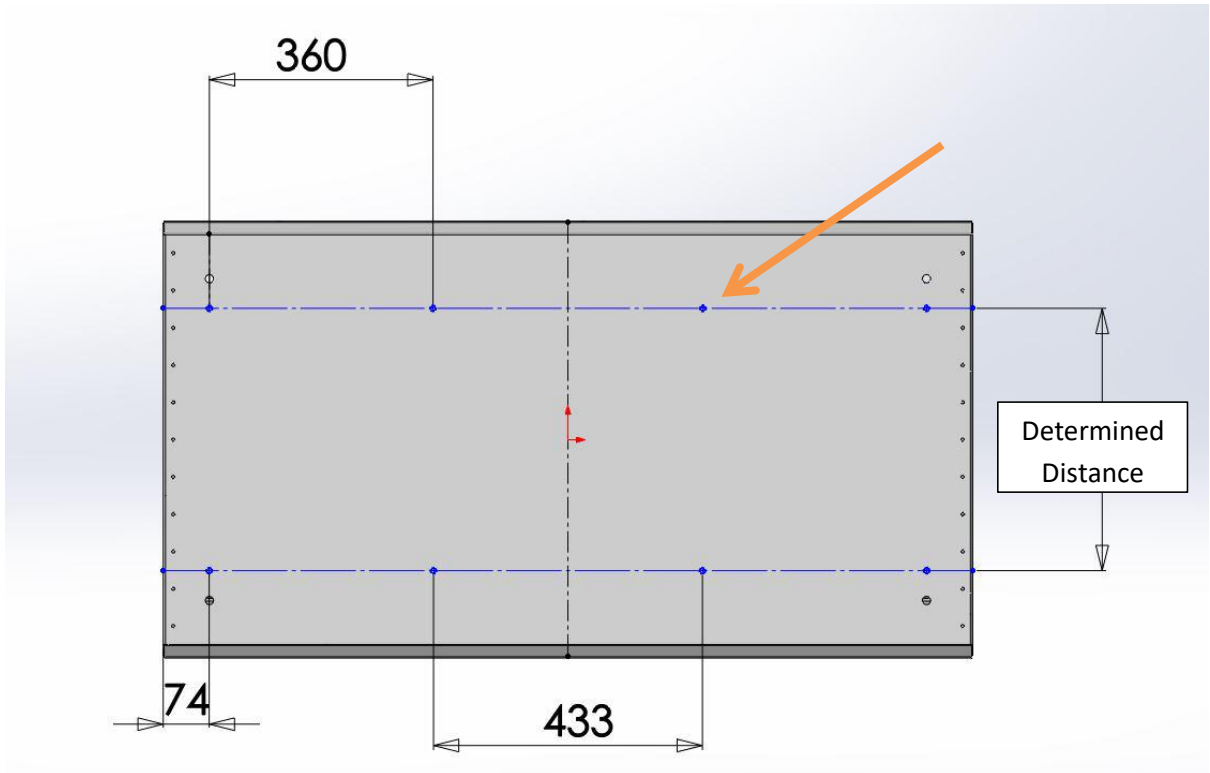

Figure 4: Pilot Hole Positioning for Mounting Holes

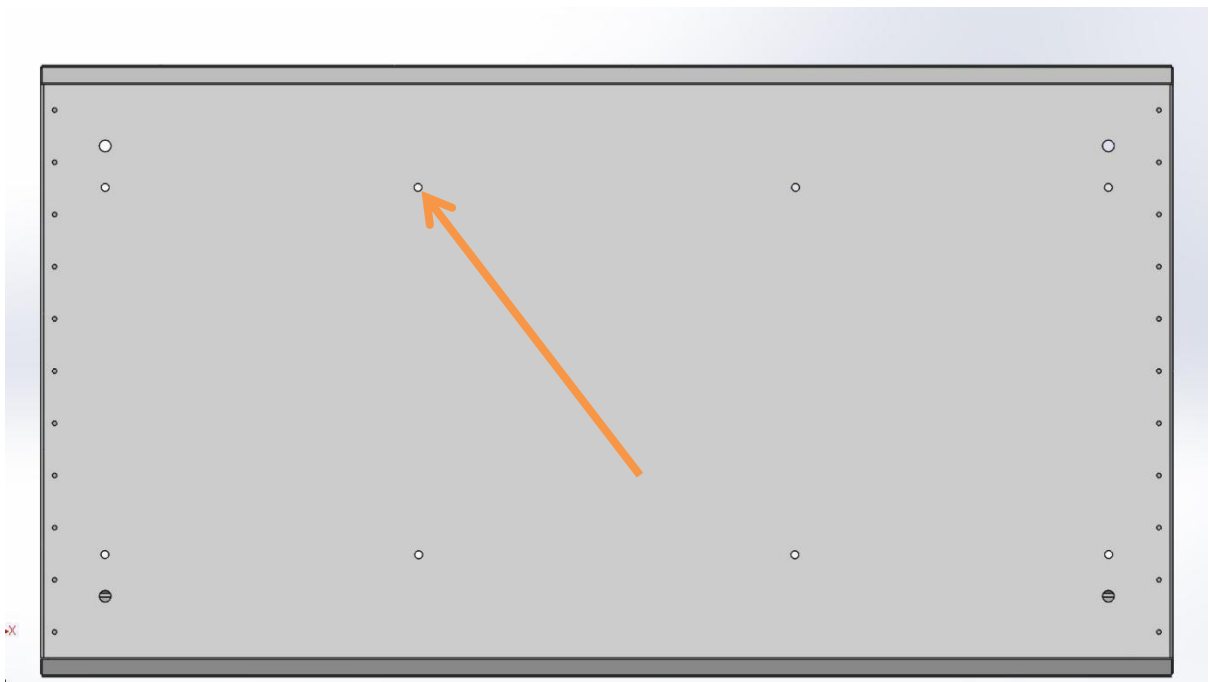

Figure 5: Mounting Holes Drilled

*Please note, Hole and Mounting will be Gear and Vehicle Specific, where your Load Bars are Mounted and Positioned will determine the measurements, as well as what other Gear is on the vehicle, this is an example.

Step 3: Rubber Strips

You are provided in your Roof Box Kit with 2x Flat Rubber Strips, these fit in between the Roof Box and Load Bars to shock absorb and minimize vibration and noise. We must place the Rubber Strips running along the Mounting Holes on the base of the Roof Box, and drill through the Rubber where our Mounting Holes are, using the 9mm drill bit.

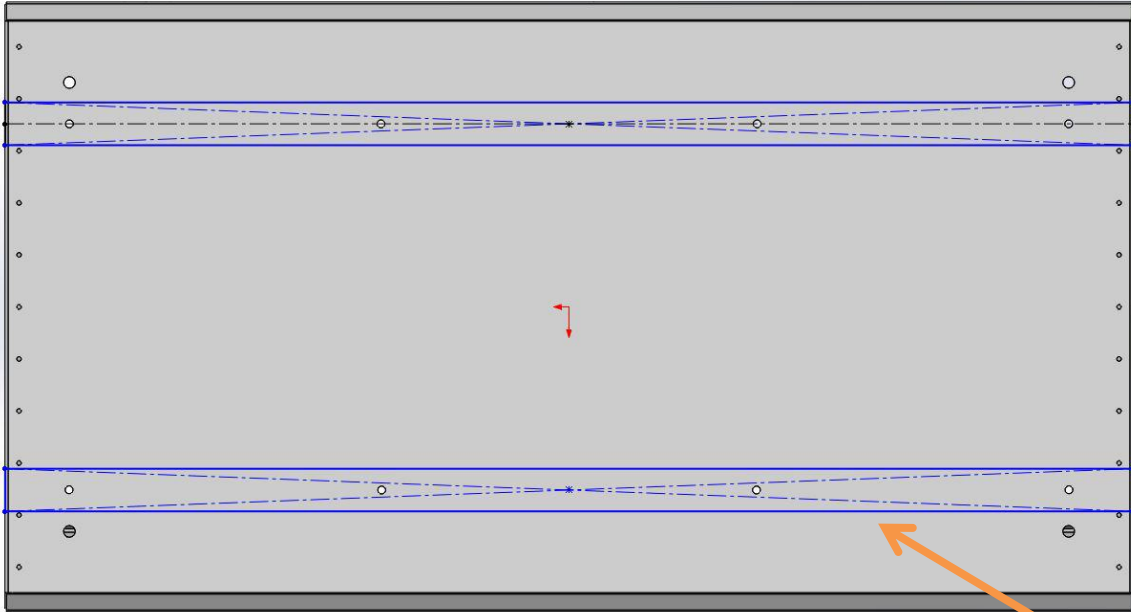

Figure 6: Rubber Strip Placement

Step 4: Bolts and Rubber Strip Fit

This next step entails us inserting the 8x M8x20 Hex Head Bolts into the top Nut slots of the Load Bars, 4 per Load Bar. We will then place the Rubber Strips over the Bolts, using the Rubber Strips and hole cut-outs to position the Bolts along the Load Bars, making the alignment and fitment of the Roof Box easier.

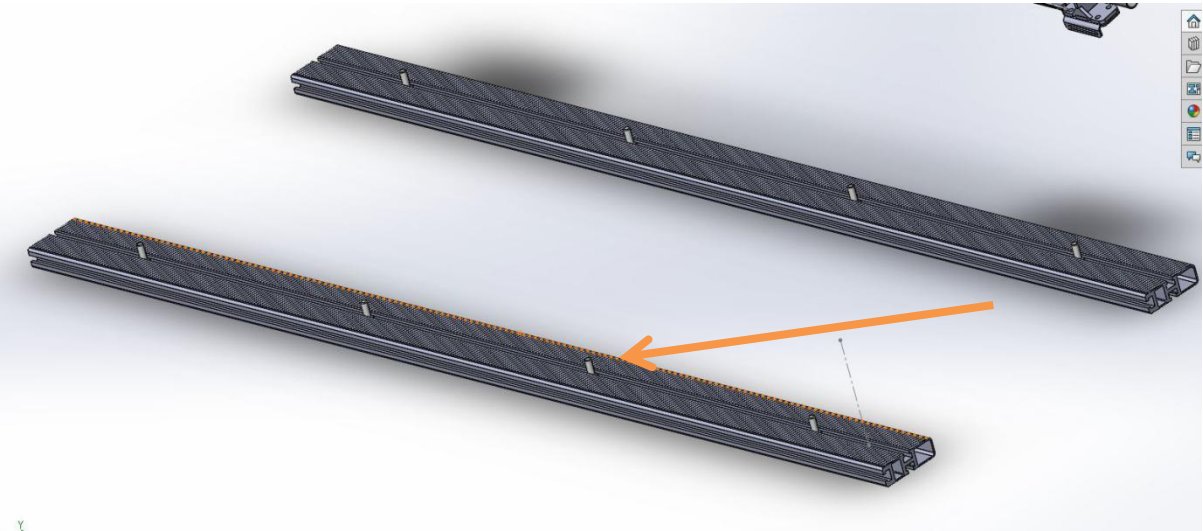

Figure 7: Mounting Bolts in Nut Slots

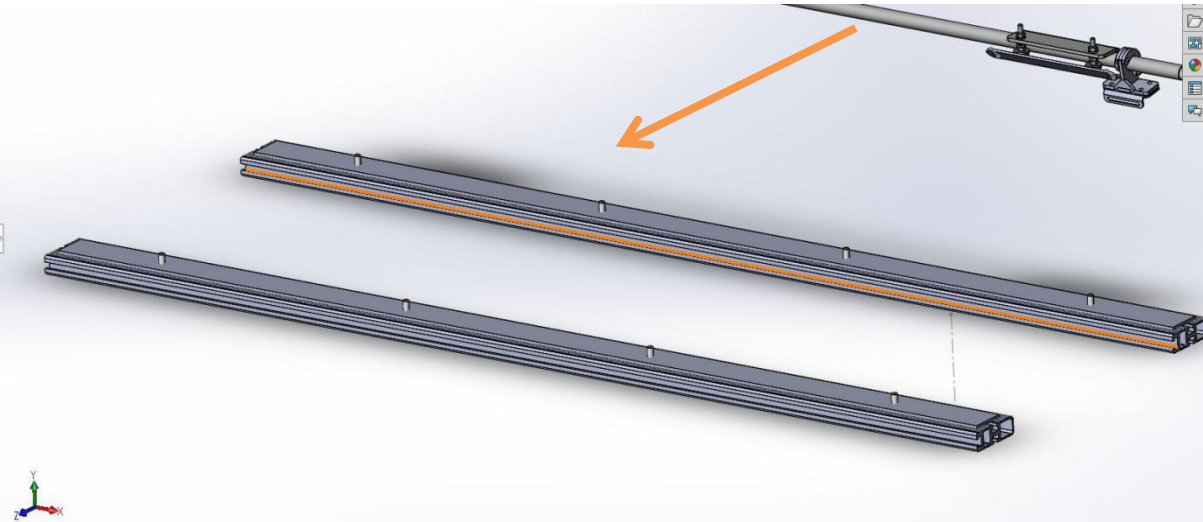

Figure 8: Rubber Strips over Mounting Bolts

Step 5: Roof Box Placement

We now need to place and position our Roof Box on the Load Bars using our Mounting Holes. The Roof Box will be placed resting on top of the Bolts, where it will then further be positioned until all the Bolts are through the Mounting Holes.

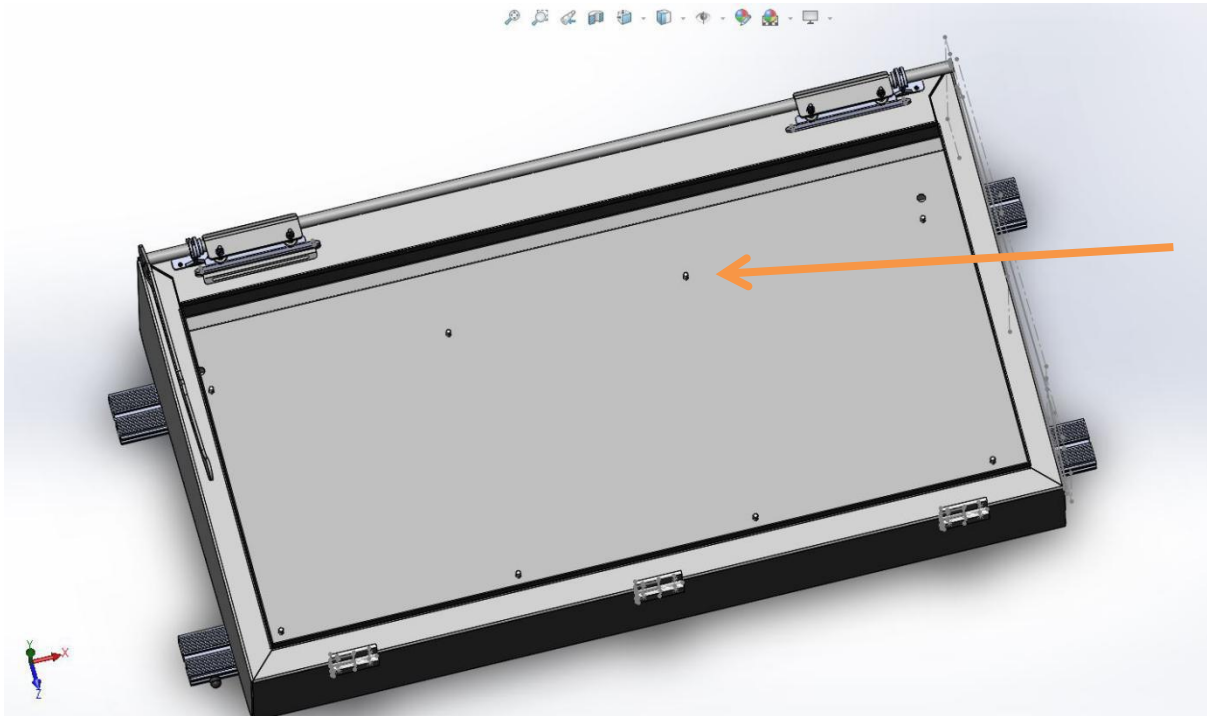

Figure 9: Roof Box on positioned on top of Load Bars

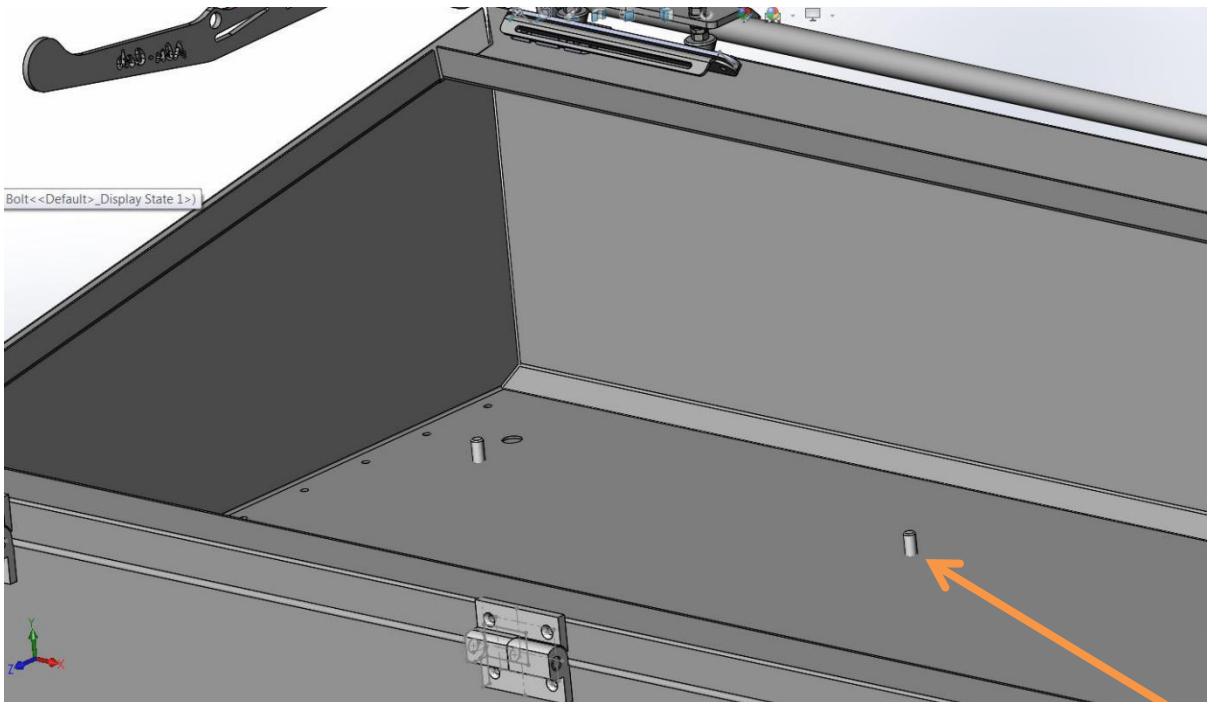

Figure 10: Bolts Through the Mounting Holes

Step 6: Roof Box Fastening

Now that the Roof Box has been positioned on the Load Bars and the Bolts are through the Base, we can proceed to fastening the Roof Box securely. There will be 8 Mount Plates that are provided in your kit, 1 for each Bolt, these need to be placed over each Bolt and fastened tightly using an M8 Nyloc Nut. Once this has been done for all 8, they can be finished by adding on a Plastic Nut Cap on each nut.



Figure 11: Nyloc Nut and Mount Plate

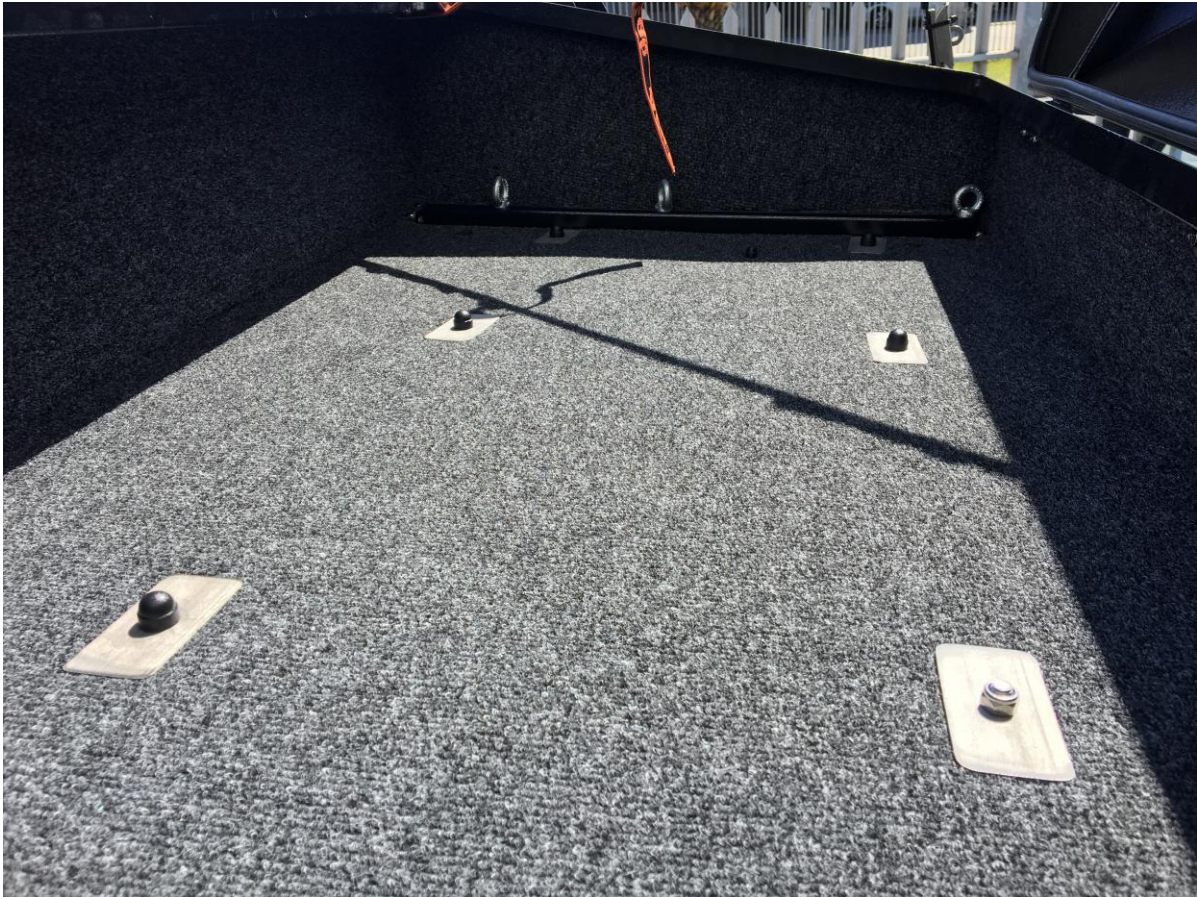

Figure 12: Mounting Plates Placement

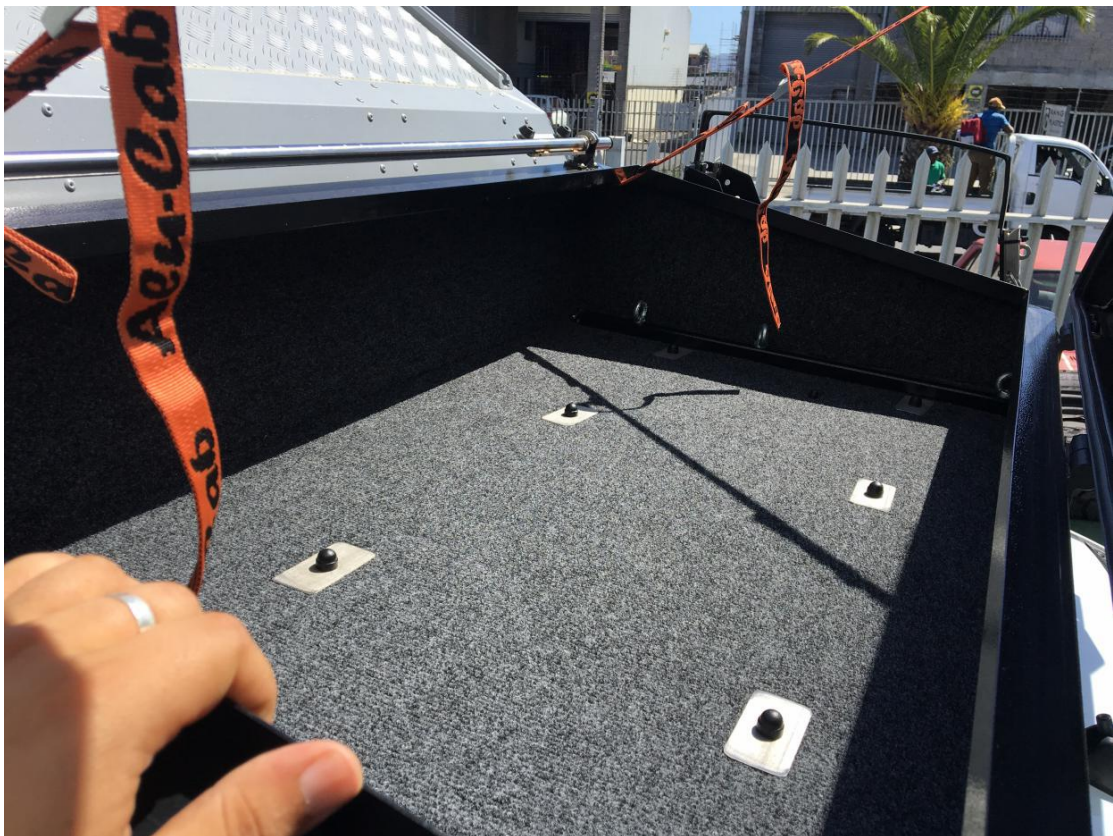

Figure 13: Fastened Roof Box



Figure 14: Completed Roof Box Securely Fastened